



# DROP-IN Seats

## Installation Guidelines

### Using the RMS Lock & Latch System

EN

MD



#### IMPORTANT NOTES:

- Please read instructions and refer to diagram before attempting to fit this product.
- For safety, correct support and user comfort, a suitably qualified person should carry out the initial installation of this Drop-In Seat.
- If the Drop-In Seat is being used in conjunction with an RMS backrest, the Drop-In Seat should be fitted first.
- As the fitting of this seat could raise the user's position, this may affect the wheelchair stability. It is therefore recommended that, on completion of this installation, an appropriate stability test be carried out, by a suitably qualified person.
- Lock & Latch mounting clamp sets are available to suit three sizes of frame tube, 19, 22 and 25mm, please ensure therefore, that the Lock & Latch system supplied with this seat, is the correct size for your application prior to commencing installation.

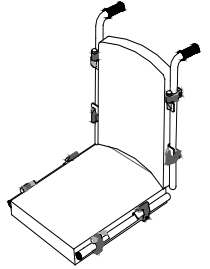

#### TOOLS REQUIRED: As necessary to remove original seat canvas.

- Flat Bladed Screwdrivers with blade width of approximately 6mm.
- 3mm Hexagon Key
- Pozi-drive Screwdriver size 3.

#### FITTING

- With wheelchair fully open and parking brakes applied, remove original seat canvas. (Detachable side arms should be removed for easier access when fitting or removing the Drop-In Seat).
- If castor outriggers and / or anti-tip devices were prescribed at initial assessment, they should be fitted at this stage, following the fitting instructions supplied with those products.
- Position Drop-In Seat onto wheelchair, locating the seat support brackets over the original seat canvas rails. (The Seat Baseboard is shaped with cutouts to accommodate any frame cross-braces).

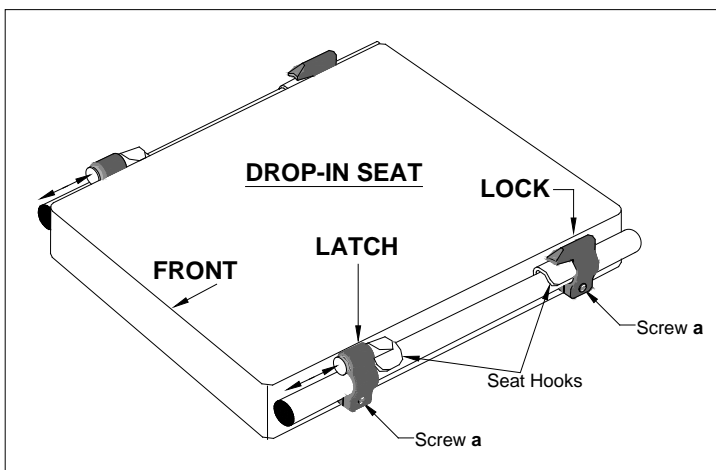

**NOTE:** To enable the Seat Hook Brackets to sit snugly over the Seat Rails, it may be necessary to slacken the M6 Bracket screws to reposition the Brackets as required. Re-tighten screws sufficient to prevent any movement.

- Lightly mark seat rails - level with back edge of rear seat hooks and front edge of front seat hooks. Lift seat clear of wheelchair frame.
- After removing screws and tube nuts (**a**) from the Lock & Latch clamps, install the Lock clamps over the seat rails behind

rear seat hook marks, (see diagram). Slide clamp forward to align front edge of Lock clamp with seat hook marks. Re-install screws and tube nuts to Lock clamps and tighten screws sufficient for clamps to maintain their position on the top of the seat rails.

- Install the Latch clamps over the seat rails just forward of the front seat hook marks, (see diagram). Slide clamp rearwards to align rear edge of Latch clamp with seat hook marks. Re-install screws and tube nuts to Lock clamps and tighten screws sufficient for clamps to maintain their position on the top of the seat rails.

PTO....

- Prior to re-installing the Drop-in Seat, pull both Latch locking pins forwards towards the front of the wheelchair, until they self-lock in the unlocked position.
- Install Drop-in Seat onto wheelchair seat rails by locating rear seat hooks under the Lock brackets then lowering the front of Seat down onto seat rails.
- Lock Seat into position by releasing both Latch locking pins. (These are spring-loaded and should locate over the front seat hooks).
- Install cushion where separate from seat board and refit wheelchair side arms.

\*\*\*\*\*

## USER / CARER Guidelines



### ADVISORY NOTES:

- Prior to removal or refitting of the Drop-In Seat, it is recommended that the wheelchair is positioned on a level, non-slip surface, with both parking brakes applied.
- Detachable sidearms should be removed for easier access when removing or refitting the seat.



### REMOVAL: (refer to diagram overleaf)

- Slide both Latch locking pins towards the front of the wheelchair until locked in the open position.
- Raise front of Seat clear of Latch brackets and slide forward until rear Seat hooks clear the Lock brackets. Lift Seat upwards and away from wheelchair.



### REFITTING: (refer to diagram overleaf)

**NOTE:** Where the Drop-In Seat is being used in conjunction with a removable backrest, it is recommended that the Drop-In Seat is installed first.

- With both Latch locking pins set to the open position i.e. pulled fully forward, lower Seat onto wheelchair seat rails with the Seat front raised to an angle of approximately 20 degrees.
- Allow rear Seat hooks to engage under Lock brackets and lower front of Seat onto rails.
- Release Latch locking pins to the locked position, i.e. fully rearwards, (These are spring-loaded and should locate over the front seat hooks).



### WARNINGS:



- Users, carers or attendants should be aware of any possible hygiene risks to themselves and others.



- All reasonable steps should be taken to ensure hygienic use of the Drop-in Seat which should be cleaned on a regular basis, using a sponge with warm soapy water with a little disinfectant added or, car upholstery cleaner, either can be wiped dry with a clean absorbent cloth.
- Ensure all surfaces are dry before re-use.



- It is recommended the seat be reviewed at regular intervals, by a suitably qualified person, to ensure correct fitment, security and serviceability condition.



- Avoid exposure naked flames and sources of excessive heat.

Should you require further information on this or any other product in the RMS range, please contact our Technical Help-line on 01795-477280



### Thompson House

Unit 10 Styles Close, Sittingbourne, Kent, ME10 3BF

Tel: 01795 477280 Fax: 01795 229692

E-mail address: [sales@rms-kent.co.uk](mailto:sales@rms-kent.co.uk)

[www.ineedawheelchair.co.uk](http://www.ineedawheelchair.co.uk)



FM 661078

DIS-IFU-2021-rev0

Dec 2021

